

TPS2300, TPS2301

Dual Hot Swap Controller Evaluation Module and Interface Card

User's Guide

IMPORTANT NOTICE

Texas Instruments and its subsidiaries (TI) reserve the right to make changes to their products or to discontinue any product or service without notice, and advise customers to obtain the latest version of relevant information to verify, before placing orders, that information being relied on is current and complete. All products are sold subject to the terms and conditions of sale supplied at the time of order acknowledgment, including those pertaining to warranty, patent infringement, and limitation of liability.

TI warrants performance of its semiconductor products to the specifications applicable at the time of sale in accordance with TI's standard warranty. Testing and other quality control techniques are utilized to the extent TI deems necessary to support this warranty. Specific testing of all parameters of each device is not necessarily performed, except those mandated by government requirements.

Customers are responsible for their applications using TI components.

In order to minimize risks associated with the customer's applications, adequate design and operating safeguards must be provided by the customer to minimize inherent or procedural hazards.

TI assumes no liability for applications assistance or customer product design. TI does not warrant or represent that any license, either express or implied, is granted under any patent right, copyright, mask work right, or other intellectual property right of TI covering or relating to any combination, machine, or process in which such semiconductor products or services might be or are used. TI's publication of information regarding any third party's products or services does not constitute TI's approval, warranty or endorsement thereof.

Contents

1	Introduction	1-1
1.1	TPS2300 and TPS2301	1-2
1.2	EVM and Interface Card Schematics	1-2
1.3	Layouts of the EVM and the Interface Card	1-5
1.4	Setup of the EVM	1-6
1.5	Changeable Components and Test Points on the Hot-Swap EVM	1-7

Figures

1-1	Hot-Swap Evaluation Module (EVM) Schematic	1-3
1-2	Interface Card Schematic	1-3
1-3	Top Layer of the Hot-Swap EVM, and Placement of Components	1-5
1-4	Top Layer of the Interface Card, and Placement of Components	1-6

Tables

1-1	Components on the TPS2300, TPS2301 EVM Hot-Swap EVM (SLVP153)	1-4
1-2	Components on the Interface Card (SLVP155)	1-5



Introduction

The TPS2300 and TPS2301 are new Texas Instruments hot-swap controllers that eliminate high-frequency hot-plug or hot-removal transients, reduce in-rush current, and provide overcurrent protection. The evaluation module (EVM) and interface card can help designers evaluate the devices and simulate hot-insertion and hot-removal actions under various conditions.

Users will need at least one dc voltage supply to test the operation of the EVM.

Topic	Page
1.1 TPS2300 and TPS2301	1-2
1.2 EVM and Interface Card Schematics	1-2
1.3 Layouts of the EVM and the Interface Card	1-5
1.4 Setup of the EVM	1-6
1.5 Changeable Components and Test Points on the Hot-Swap EVM	1-7

1.1 TPS2300 and TPS2301

Both the TPS2300 and TPS2301 are dual-channel hot-swap controllers that use external N-channel MOSFETs as high-side switches in power applications. The devices integrate features such as overcurrent protection, inrush-current control, output-power status reporting, and separation of load transients from actual load increases, which are the critical requirements for hot-swap applications. The only difference between TPS2300 and TPS2301 is the polarity of the enable pin.

For a detailed description of functions and characteristics of the TPS2300 and TPS2301, refer to the data sheet (literature number SLVS265A). Check data sheet and ordering information on web site:

<http://www.ti.com/sc/docs/products/analog/tps2300.html>

The minimum number of external parts for each channel is four: an N-channel MOSFET, a current-sense resistor, a current-limit-setting resistor, and a timing capacitor. Refer to the data sheet to select appropriate values for these components. For different applications, a gate capacitor may be required to limit excessive inrush current or very heavy load, and input capacitors can help to hold the input voltage in the designed range.

To assist designers in evaluating the hot-swap controllers, TI has developed a set of evaluation modules based on the active-high-enabling TPS2301. The modules are: the hot-swap EVM and the interface card.

1.2 EVM and Interface Card Schematics

To demonstrate a hot-plug or hot-removal application, the EVM set includes two boards: one is the hot-swap EVM (SLVP153), where the TPS2301 is mounted for control of power MOSFETs; the other is an interface card (SLVP155) that supplies power and control signals to the hot-swap EVM.

Figures 1–1 and 1–2 show the schematic of the hot-swap board and the schematic of the interface card, respectively.

Figure 1–1. Hot-Swap Evaluation Module (EVM) Schematic

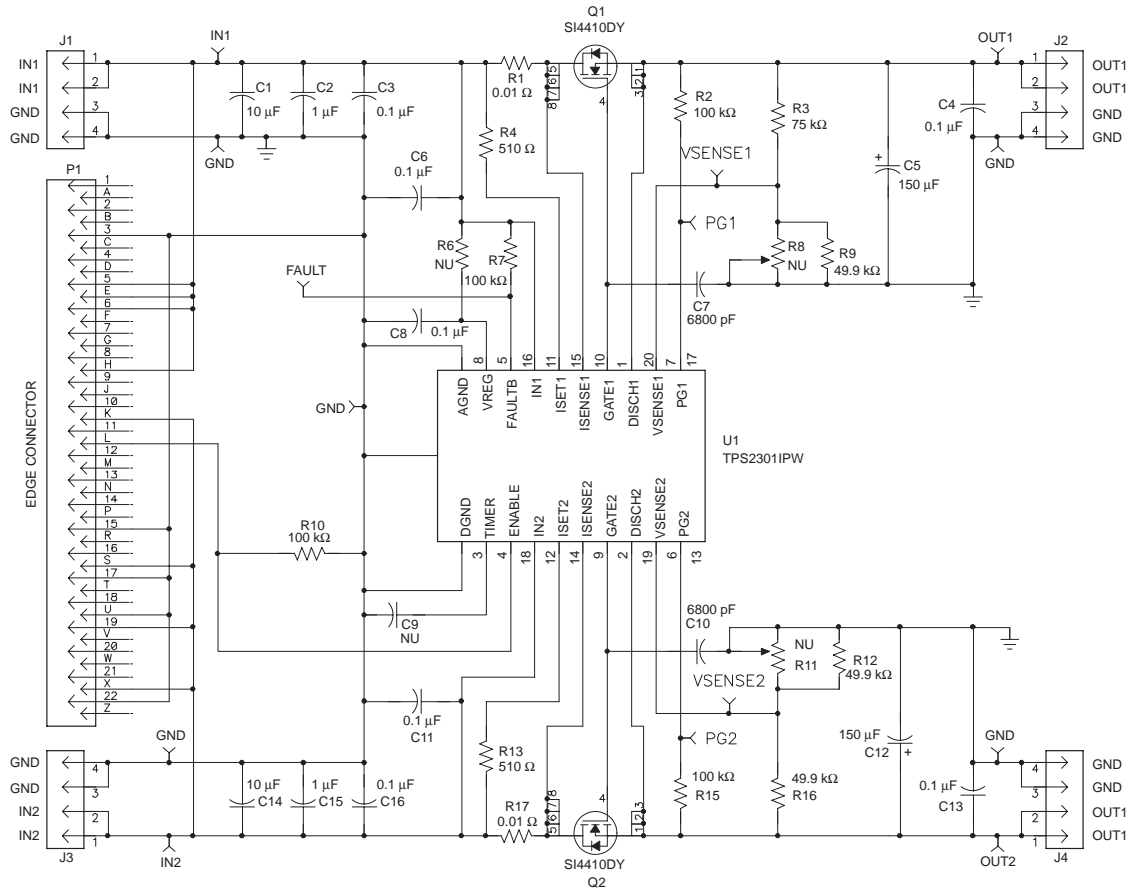
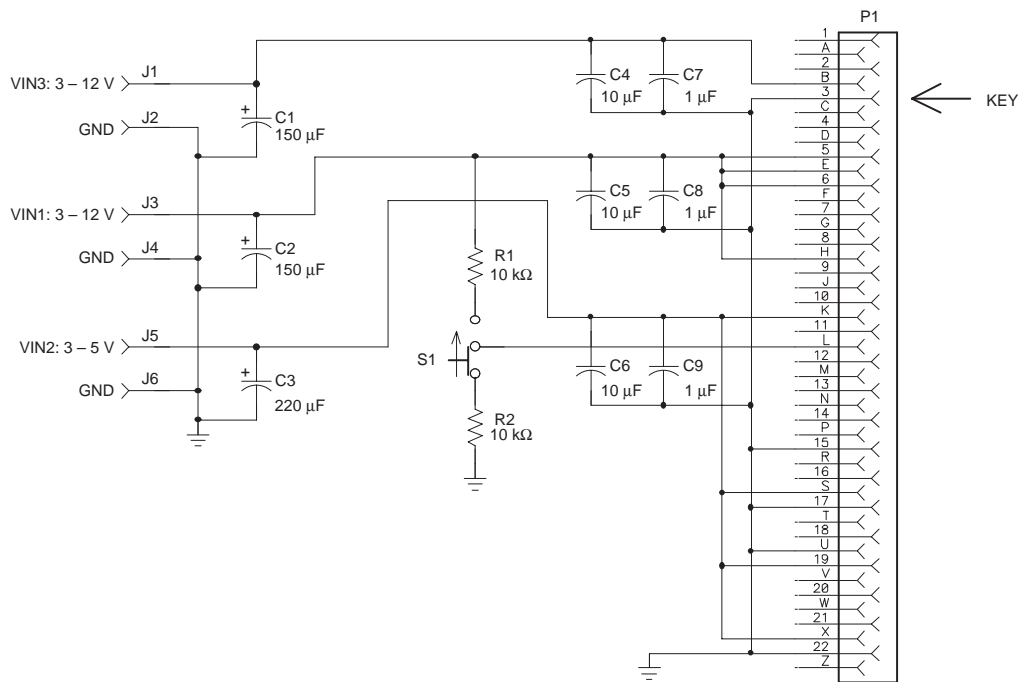

Figure 1–2. Interface Card Schematic



The figures show that the hot-swap EVM board has two supply inputs: IN1 and IN2; but the interface board has three supplies available. VIN3 on the interface board is not used for the evaluation of the dual hot-swap EVM board.

Additionally, a key is installed in the edge connector on the interface board to prevent plugging the hot-swap board in the wrong direction.

The bills of materials (BOM) for the boards are shown in Tables 1–1 and 1–22.

Table 1–1. Components on the TPS230 EVM Hot-Swap EVM (SLVP153)

Reference	Qty.	Part Number	Description	MFR.
C1, C14	2	GRM235Y5V106Z016A	Capacitor, ceramic, 10 μ F, 16 V, 80%–20%, Y5V	TDK
C2, C15	2	ECJ-2VF1C105Z	Capacitor, ceramic, 1 μ F, 16 V, 80%–20%, Y5V	Panasonic
C3, C4, C6, C8, C11, C13, C16	7		Capacitor, ceramic, 0.1 μ F, 25 V, 10%, X7R	Murata
C5, C12	2	TPSD157M016R150	Capacitor, tantalum, 150 μ F, 16 V, 150-m Ω , 20%	AVX
C7, C10	2		Capacitor, ceramic, 6800 pF, 50 V, 10%, X7R	Murata
C9			NU	
J1–J4	4	PTC36SAAN	Header, single-row, straight, 4-pin, 0.1" \times 25 mil	Sullins
Q1, Q2	2	Si4410DY	MOSFET, N-ch, 30-V, 10-A, 13-m Ω	Siliconix
R1, R17	2	WSL-2512 0R01 1%	Resistor, chip, 0.010 Ω , 1 W, 1%	Vishay
R2, R7, R10, R15	4	ERJ-8GEYJ104V	Resistor, chip, 100 k Ω , 1/8 W, 5%	Panasonic
R3	1	ERJ-8ENF7502V	Resistor, chip, 75 k Ω , 1/8 W, 1%	Panasonic
R4, R13	2	ERJ-8GEYJ511V	Resistor, chip, 510 Ω , 1/8 W, 5%	Panasonic
R6			NU	
R8			NU	
R9, R12, R16	3	ERJ-ENF4992V	Resistor, chip, 49.9 k Ω , 1/8 W, 1%	Panasonic
R11			NU	
TP1,2,5–7,9,10,13, 14	9	240-345	Test point, red, 1 mm	Farnell
TP3,4,8,11,12	5	240-333	Test point, black, 1 mm	Farnell
U1	1	TPS2301IPW	IC, dual hot-swap power controller with independent circuit breaker and power-good reporting	TI

Capacitors C1 and C14 are ceramic capacitors for reducing spikes and noises. If the environment of an application is not severe, they can be removed or their values can be reduced. Load capacitors C5 and C12 can be changed according to requirements of the loads.

Table 1–2. Components on the Interface Card (SLVP155)

Reference	Qty.	Part Number	Description	MFR.
C1, C2	2	TPSD157M016R150	Capacitor, tantalum, 150 μ F, 16 V, 150 μ W, 20%	AVX
C3	1	10TPB220M	Capacitor, POSCAP, 220 μ F, 10 V, 40 μ W, 20%	Sanyo
C4, C5, C6	3	GRM235Y5V106Z016A	Capacitor, ceramic, 10 μ F, 16 V, 80%–20%, Y5V	TDK
C7, C8, C9	3	ECJ-2VF1C105Z	Capacitor, ceramic, 1 μ F, 16 V, 80%–20%, Y5V	Panasonic
J1–J9	6	3267	Connector, banana jack, uninsulated	Pomona
P1	1	50-22SN-11	Connector, 44-pin edge w/mtg tabs (for 0.062" PCB)	Cinch
R1, R2	2	ERJ–8GEYJ103V	Resistor, chip 10 k Ω , 1.8 W, 5%	Panasonic
S1	1	EG1218	Switch, 1P2T, slide, PC-mount, 200-mA	E-Switch
TP1–TP3	3	240-345	Test point, red, 1 mm	Farnell
TP4–TP6	3	240-333	Test point, black, 1 mm	Farnell

1.3 Layouts of the EVM and the Interface Card

Figures 1–3 and 1–4 illustrate the placements of the components and the top-layer layouts for the hot-swap EVM board and the interface card, respectively. All components are placed on the top layers only. The bottom layers are ground planes except for a few short traces on the hot-swap EVM.

Figure 1–3. Top Layer of the Hot-Swap EVM, and Placement of Components

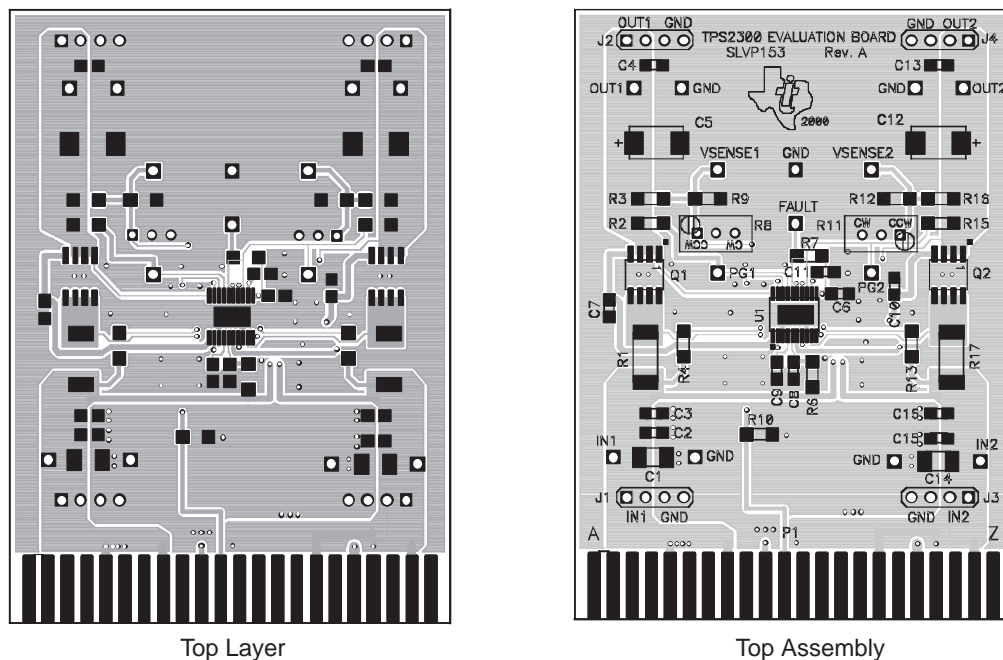
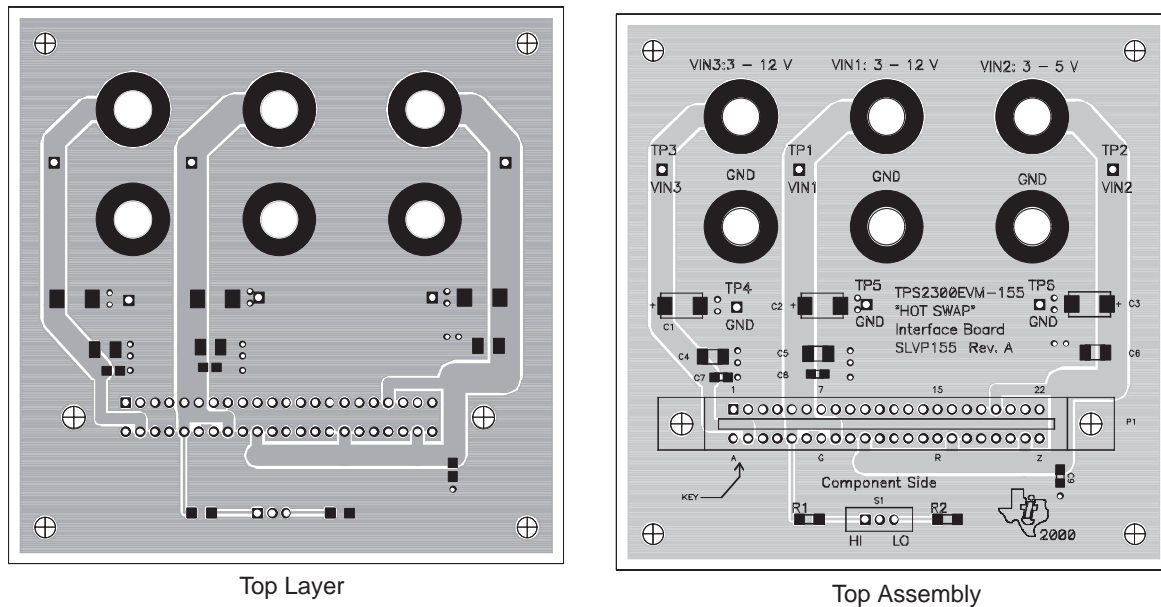

Figure 1–4. Top Layer of the Interface Card, and Placement of Components



1.4 Setup of the EVM

For proper operation of the EVM, follow these steps for dual hot-swap evaluation:

- 1) Verify that the power-supply voltages are in the required ranges:
 $3\text{ V} < \text{Supply \#1} < 13\text{ V}$; $3\text{ V} < \text{Supply \#2} < 5.5\text{ V}$. Make sure the supplies have the capability to supply the current that the loads need. Turn off the supplies.
- 2) Plug the supplies into the interface card: connect Supply #1 to IN1, and Supply #2 to IN2. Turn on both power supplies.
- 3) Loads can be connected to the outputs (between OUT1 and GND, and between OUT2 and GND) of the hot-swap board if users want to simulate resistive or current loads. However, users can test a number of characteristics of the controller without external loads.

Because the sense resistor on the EVM is $0.01\ \Omega$, and the current-limit-setting resistor is $510\ \Omega$, the maximum dc current each channel can supply is (refer to TPS2300/TPS2301 data sheet):

$$I_{LMT1} = \frac{R_{SET1} \times 50 \times 10^{-6}}{R_{S1}} = \frac{510 \times 50 \times 10^{-6}}{0.01} = 2.55\text{ A}$$

But, the actual current it can pass will be lower than 2.55 A since the contact resistance and PCB trace resistance cannot be neglected compared to the $0.01\ \Omega$. Considering the effect of these resistances, the actual current limits for both channels are about 1.4 A for the present settings on the hot-swap board.

Users can increase the current limit by increasing the resistance of the setting resistor R4 or R13, or by reducing the sense resistance of R1 or R17 for the respective channel. However, the maximum current should not exceed the current capability of the external MOSFET and the connectors on the board.

- 4) Set switch S1 on the interface board to HI to hot-plug the hot-swap board into the power supplies. If S1 is set to LO when plugging the hot-swap board into the supplies, the power will not be connected to the loads, because the TPS2301 is an active-high-enabling device.
- 5) Test points are provided for oscilloscope probes and/or multimeters.
- 6) Plug the hot-swap board into the interface board. The key installed between pins 4 and 5 of the connector insures that the board can only be inserted in the correct direction.

1.5 Changeable Components and Test Points on the Hot-Swap EVM

C5, C12 – Load capacitors, vary according to loads.

C7, C10 – Gate capacitors, to further limit inrush current. If load capacitance C5 or C12 is increased, the respective gate capacitance in the same channel should be increased accordingly.

C9 – Timing capacitor, a minimum 50-pF capacitor is strongly recommended. For very heavy load applications, its value must be increased accordingly.

R1, R17 – 0.01 Ω , 1-W sense resistors

R4, R13 – Current-limit-setting resistors

R3, R9, R16, R12, R8, R11 – Output low-voltage-sensing feedback resistors, R8 is in parallel with R9, and R11 is in parallel with R12. These resistors are potentiometers that can be used to adjust VSENSE1 or VSENSE2 voltage levels to verify the integrated power-good circuitry works. When using R8 and R11, R9 and R12 should be removed.

R6 – Not used. EVM users can solder a 10- Ω 1206 resistor to short IN1 and VREG when IN1 voltage is less than 5.5 V. However, this modification will consume more supply current during shutdown mode.

Test points available on the board are:

GND, IN1, IN2, FAULT, PG1, PG2, VSENSE1, VSENSE2, OUT1, OUT2.

